

## CHARACTERISTIC

- Gradual changed pitch, high ultimate pressure, large pumping capacity and fast exhaust.
- Energy-saving design, 30% reduction in power consumption.
- Special profile design, few medium gas condensation.
- Spiral jacket cooling, low exhaust temperature, no carbonization, prevents jamming, long service life.
- Internal no oil or water, no waste oil wastewater treatment, facilitating solvent recovery.
- Configurable gas seal, inlet purging, steam cleaning, solvent cleaning.
- Corrosion-resistant coating treatment for fluid contact parts, strong anti-corrosion ability.



# VSP Series Screw Vacuum Pump

## VSP800 - 3000

## CONTACT DETAILS

Address: No.27-2 Xinlin North Road, Lincheng Town,  
Changxing County, Huzhou City, Zhejiang Province, China

- Cell Phone: +86-198-5725-1787
- WhatsApp: +8619857251787
- Website: [www.vacculex.com](http://www.vacculex.com)
- Email: [eddy@vacculex.com](mailto:eddy@vacculex.com)



**Vacculex Vacuum Equipment  
(Zhejiang) Co.,Ltd.**

## PARAMETER

Model	Unit	VSP800		VSP1000		VSP1500		VSP3000	
Frequency	Hz	50	60	50	60	50	60	50	60
Exhaust Volume	m <sup>3</sup> /h	660	800	1250	1500	1250	1500	2250	2700
	L/s	183.3	222.2	347.2	416.6	347.2	416.6	625	750
Ultimate Vacuum	Torr	7.5×10 <sup>-2</sup>							
	Pa	10							
Motor Power	Kw	15	18.5	18.5	22	30	37	45	55
Rotation Speed	rpm	2900	3500	2900	3500	1450	1750	1450	1750
Exhaust Method		Side Exhaust/Bottom Exhaust				Side Exhaust			
Inlet Connection	JIS 10k	JIS100		JIS125		JIS125		JIS150	
Exhaust Connection	JIS 10k	JIS65		JIS80		JIS80		JIS100	
Cooling Water Flow	l/min	15 ~ 20		30 ~ 40		30 ~ 40		40 ~ 50	
Cooling Water Connection	NPT	NPT1/2		NPT 1/2		NPT 1		NPT 1	
Gearbox oil volume	l/min	2.5		3		8		10	
Seal Purge Gas	l/min	15 ~ 25							
Pump Weight	Kg	580		750		1600		2500	

## DIMENSIONS

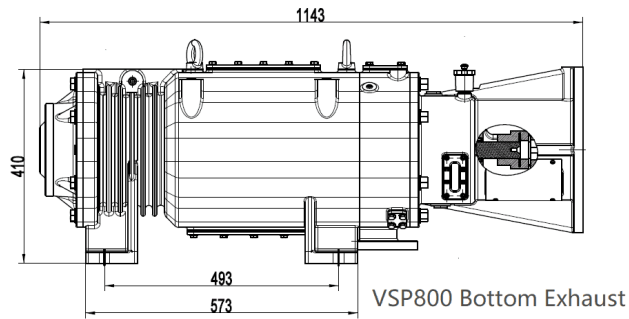

## DIMENSIONS

